

120x120x38mm (4.72x4.72x1.50in) - 5 blade

Bearing System— 2 Ball Bearing,
 Life Expectancy--- Ball 50000hrs@ 25°C
 Frame----- Aluminum
 Impeller----- Thermoplastic PBT+15% GF, UL94V-0
 Lead Wire----- UL 1007, AWG 22, 300±10mm, Black
 Protection----- Locked rotor protection
 IP Grade ----- Optional

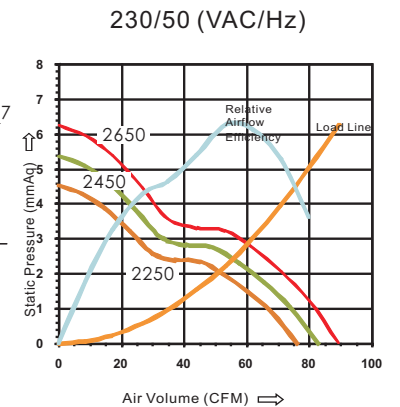
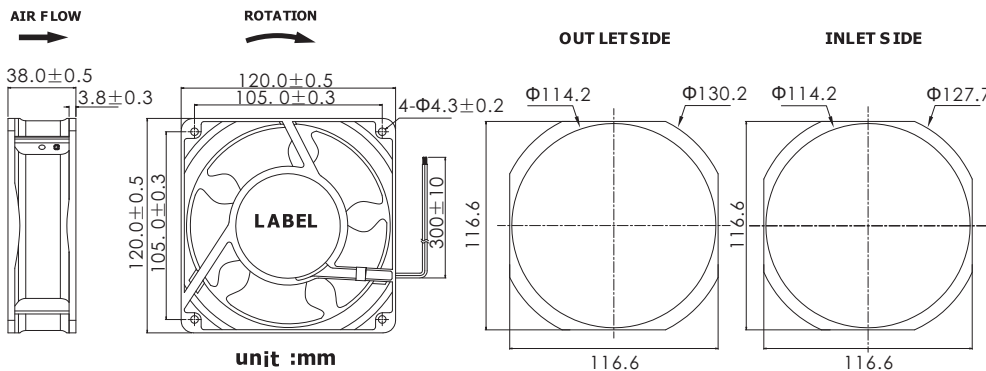
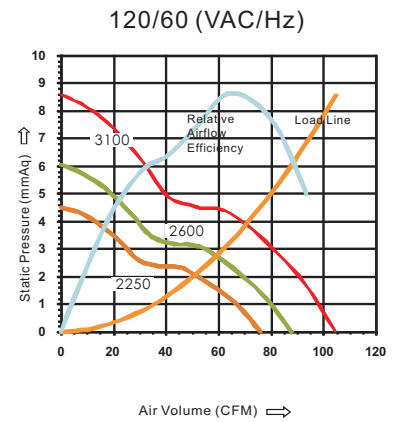

FUNCTIONS	PART NUMBER	VOLTAGE/RANGE (VAC)	LABEL CURRENT	ACTUAL CURRENT	POWER (WATTS)	SPEED (RPM)	AIRFLOW (CFM)(m³/min)	PRESSURE (mmAq)(In H²O)	NOISE (dBA)	WEIGHT (Q'TY/CTN)
	PM1238HA1BAL-5	120/60 100~125	0.21	0.204	15.7	3100	104.67 2.96	8.56 0.34	45.0	516g (30pcs)
	PM1238MA1BAL-5		0.09	0.109	8.90	2600	87.79 2.48	6.02 0.24	41.5	
	PM1238LA1BAL-5		0.08	0.091	7.50	2250	75.97 2.15	4.51 0.17	35.5	
	PM1238HA2BAL-5	230/50 200~240	0.11	0.092	19.5	2650	89.48 2.54	6.25 0.25	41.0	
	PM1238MA2BAL-5		0.06	0.060	9.80	2450	82.72 2.34	5.34 0.21	37.5	
	PM1238LA2BAL-5		0.05	0.050	8.50	2250	75.97 2.15	4.51 0.17	35.5	

Dim: 500x430x155mm
 N.W.: 15.4 kgs
 G.W.: 17.8 kgs
 Q'TY: 30 pcs



IATF16949:2016
 ISO 9001:2015
 ISO 14001:2015