

**92x92x25mm (3.62x3.62x0.98in) - 7 blade**

Bearing System— 2 Ball Bearing,  
 Life Expectancy--- Ball 50000hrs@ 25°C  
 Frame----- Aluminum  
 Impeller----- Thermoplastic PBT+15% GF, UL94V-0  
 Lead Wire----- UL 1007, AWG 22, 300±10mm, Black  
 Protection----- Locked rotor protection  
 IP Grade ----- Optional

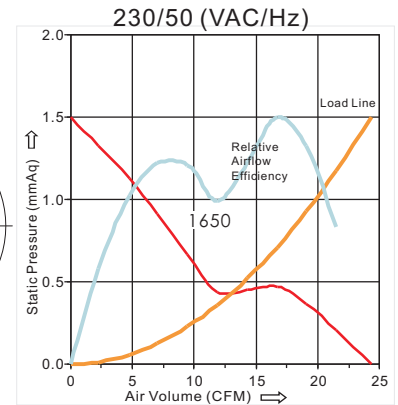
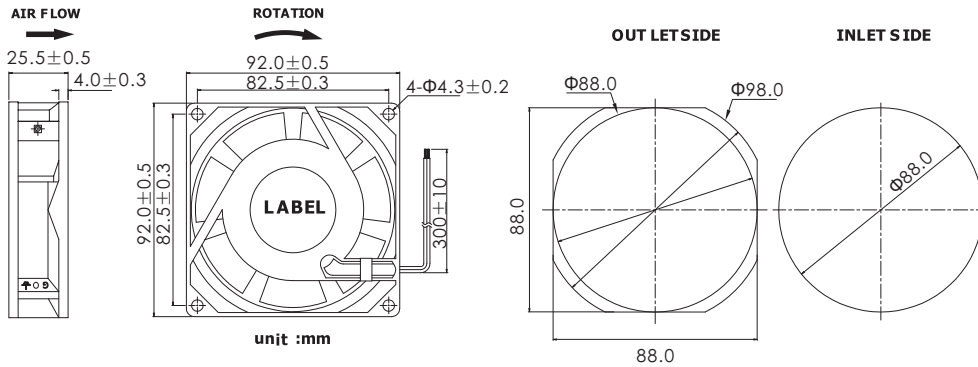
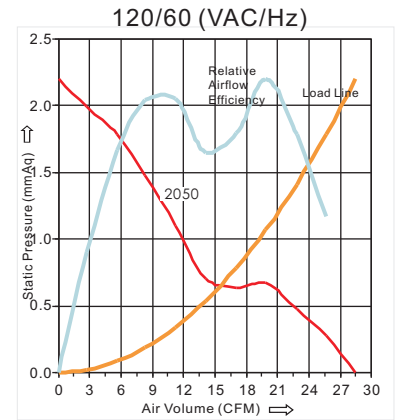

FUNCTIONS	PART NUMBER	VOLTAGE/RANGE (VAC)	LABEL CURRENT	ACTUAL CURRENT	POWER (WATTS)	SPEED (RPM)	AIRFLOW (CFM)(m³/min)	PRESSURE (mmAq)(In H²O)	NOISE (dBA)	WEIGHT (Q'TY/CTN)
	PM9225HA1BAL-7	120/60 100~125	0.09	0.075	9.30	2050	28.5 0.80	2.20 0.08	24.0	230g (60pcs)
	PM9225HA2BAL-7	230/50 200~240	0.05	0.047	9.10	1650	24.3 0.68	1.50 0.05	20.0	

Dim: 360x335x225mm  
 N.W.: 13.8 kgs  
 G.W.: 14.8 kgs  
 Q'TY: 60 pcs

